

**WDA500**  
**WD1500**

Capacity 1,100 / 3,300 lbs



## Wheel dollies

Wheel dollies for vans, trucks and buses (WDA 500)  
And for agricultural and industrial machinery (WD 1500)

- The WDA 500 is a flexible and ergonomic wheel dolly for the easy lifting of wheels, fuel tanks, tool boxes, brake drums, etc.
- The WD 1500 is specially designed for agricultural and industrial wheels with larger diameters and width. Also for deep treaded tractor tyres.

- Side adjustable lifting arms for variable wheel
- Lifting arms with roller bearings for easy rotation of the wheel into correct position.
- Robust and easy to use wheel retaining bracket in combination with the heavy duty wheels makes maneuvering of the dolly easy and safe.

## Option



### Crane arm for disc brakes, callipers, etc.

- Mounted with the telescopic crane arm the wheel trolley is a universal lifting tool
- The crane arm offers efficiency and good ergonomics when lifting disc brakes, brake drums, callipers, etc.
- The crane arm easily swivels to one side to allow wheel removal operations to be carried out
- Fitted with 360° pivoting hook
- Only for model WDA500

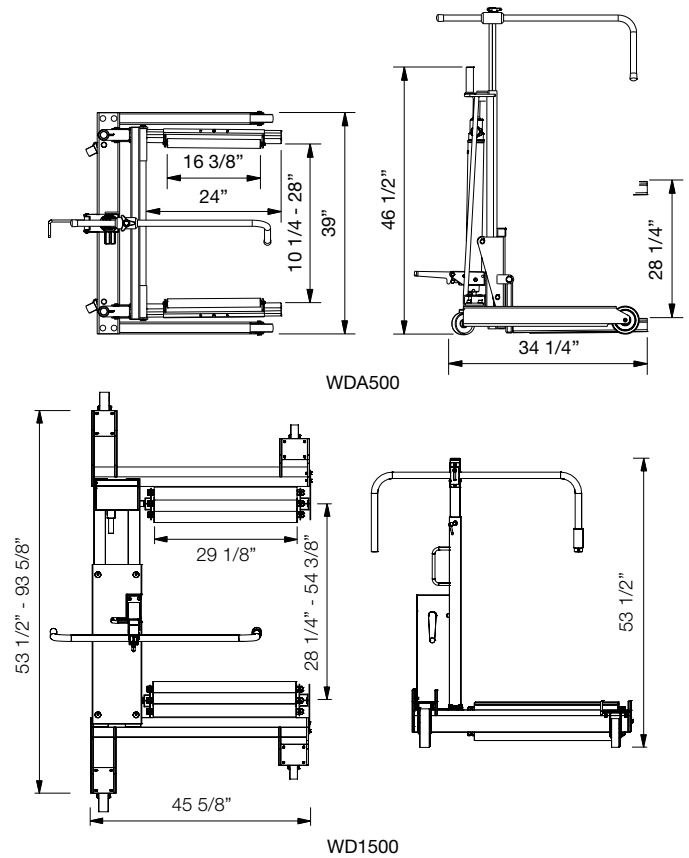

|                 | WDA500        | WD1500            |
|-----------------|---------------|-------------------|
| Height          | 46 1/2"       | 53 1/2"           |
| Length          | 34 1/4"       | 45 5/8"           |
| Width           | 39"           | 53 1/2" - 93 5/8" |
| Roller length   | 16 3/8"       | 29 1/8"           |
| Fork length     | 24"           |                   |
| Roller distance | 10 1/4" - 28" | 28 2/8" - 54 3/8" |
| Lifting height  | 28 1/4"       |                   |
| Roller diameter |               | 3 1/8"            |
| Wheel sizes     | 10 5/8" - 51" | 36 1/4" - 90 1/2" |
| Weight          | 220 lbs       | 330 lbs           |

**stertil KONI**

 a member of the Stertil Group

Stertil-Koni U.S.A. Inc.  
 200 Log Canoe Circle  
 Stevensville, Maryland 21666  
 Tel. 410-643-9001  
 Toll free 800-336-6637  
 Fax 410-643-8901  
 lifts@stertil-koni.com

www.stertil-koni.com

 StertilKoniUSA

 @StertilKoniUSA